

Optimistic Approach of High Speed Downlink Packet Access

Kamna Singh

Inderprastha Engineering College Ghaziabad, India

Abstract: Wireless Broadband access to the Internet, intranet and corporate LAN will benefit greatly from WCDMA Evolved. HSDPA is described as a simple upgradation to the existing GSM (Global System for Mobile communication) infrastructure and works at the same frequency at which GSM works which is 1.9 GHz. This paper presents the gradual evolution of HSDPA for speeding the downloading procedure for wireless communication, which has come up as a first step towards WCDMA evolved.

Keyword: Fast link Adaption, Fast Hybrid ARQ

1. INTRODUCTION:

HSDPA is described as a simple upgradation to the existing GSM infrastructure. As the penetration and use of packet-data services increases and new services are introduced, end-users will require higher data rates and improved quality of service (QoS). Operators will also require more capacity in their systems[2]. Terminals such as PDAs, smart phones and PCs with high-resolution color screens, larger displays and greater memory capacity will become more common, requiring greater speed and shorter delays when downloading audio, video and large files, or playing games. WCDMA 3GPP Release 99 provides data rates of 384 kbps for wide area coverage and up to 2 Mbps for hot-spot areas, which is sufficient for most existing packet-data applications. WCDMA 3GPP Release 5 extends the specification with HSDPA. It works on the 1.9GHz frequency which is same as GSM [3].

In order to meet the increasing demand for high data-rate multimedia services, the 3rd Generation Partnership Project (3GPP) has released a new high-speed data transfer feature named High-Speed Downlink Packet Access (HSDPA). HSDPA provides impressive enhancements over WCDMA for the downlink. It offers peak data rates of up to 10 Mbps, resulting in a better end-user experience for downlink data applications, with shorter connection and response times. More importantly, HSDPA offers three- to five-fold sector throughput increase, which translates into significantly more data users on a single frequency (or carrier).

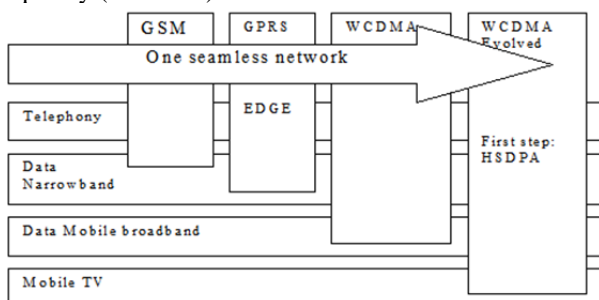

Figure 1: The Gradual Evolution of HSDPA

1.1 Advantages of WCDMA Over Previous Technologies

GSM is a spread-spectrum system based on time division in combination with frequency hopping, WCDMA is a spread-spectrum system based on direct sequence. Thus WCDMA is spectrally more efficient than GSM, but it is the wideband nature of WCDMA that provides its greatest advantage—the ability to translate the available spectrum into high data rates. This results in flexibility to manage multiple traffic types, including voice, narrowband data, and wideband data.

One enhancement over GPRS is that the control channels that normally carry signaling data can also carry small amounts of packet data, which reduces setup time for data communications. WCDMA has significantly lower network latency than GPRS/EDGE, with about 200 to 300 milliseconds (msec) measured in actual networks. Through careful planning, less than 200 msec is achievable[7].

Whereas EDGE is an extremely efficient technology for supporting low-bandwidth users, WCDMA is extremely efficient for supporting high-bandwidth users (e.g., 100 kbps and higher). In a UMTS Multi-radio network, operators can allocate EDGE channels to the low-bandwidth users and WCDMA channels to other users, thus optimizing overall network performance and efficiency. WCDMA technology gives you a faster data connection in mobile networks: currently up to 384 kbps. In future generations of WCDMA technology, this may increase up to even 10 Mbps.

1.2 WCDMA EVOLVED-HSDPA

The WCDMA air interface has been standardized by the 3rd Generation Partnership Project (3GPP) as a radio transport medium for global mobile communication systems. Consequently, the first versions of the 3GPP air interface specifications enabled superior user data rates and system throughput capacities compared to any 2nd generation mobile communication standard.

The introduction of WCDMA follows a natural evolution of 2G networks. As with the introduction of 2G networks, early 1990, it describes the first step in a continuous evolution of technologies and what technologies can provide for end-users and operators.

The term “WCDMA Evolved” describes the evolution of WCDMA addressing both operators need for efficiency and end-users demand for enhanced experience and simplicity. While the introductory phase is passed, end-user experience and enhanced system throughput is the focus of the first step of WCDMA Evolved i.e. HSDPA – High Speed Downlink Packet Access.

2. THE CONCEPT OF HSDPA

The target of the HSDPA concept is to increase the peak data rates, improve the quality of service, and enhance the spectral efficiency for downlink packet traffic. In WCDMA 3GPP release 5, WCDMA has been extended with a new transport channel, the high-speed downlink shared channel (HS-DSCH), which provides enhanced support for interactive, background, and to some extent, streaming radio access bearer (RAB) services in the downlink.

HS-DSCH transmission facilitates several new features. But to support them with minimum impact on the existing radio interface protocol architecture, a new MAC sub-layer, MAC-hs, has been introduced for HS-DSCH transmission. MAC-hs make it possible to retain a functional split between layers and nodes from WCDMA 3GPP release 99.

A minimum of architectural changes allows a smooth upgrade to HSDPA and ensures HSDPA operation in environments where not all cells have HSDPA functionality. HSDPA is based on “fat-pipe”, shared-channel transmission. Its key features are rapid adaptation to changes in the radio environment and fast retransmission of erroneous data. Therefore, the corresponding functionality must be placed close to the air interface. The HSDPA concept appears as an umbrella of features to improve both user and system performance. The higher spectral efficiency and higher speeds not only enable new classes of applications, but also support a greater number of users accessing the network.

The HSDPA concept is based on the following features:

- Shared channel transmission
- Higher-order modulation
- Short transmission time interval (TTI)
- Fast link adaptation
- Fast scheduling
- Fast hybrid automatic-repeat-request (ARQ).
- SHARED CHANNEL TRANSMISSION
- HSDPA incorporates a new transport channel type, known as High Speed Downlink Shared Channel (HS-DSCH) to facilitate air interface channel sharing between several users.
- HS-DSCH is based on shared-channel transmission, which means that some channel codes and the transmission power in a cell are seen as a common resource that is dynamically shared between users in the time and code domains. Shared channel transmission results in more efficient use of available codes and power resources in WCDMA compared to the current use of a dedicated channel (WCDMA 3GPP Release 99).
- The shared code resource onto which the HS-DSCH is mapped consists of up to 15 codes. The spreading factor (SF) is fixed at 16. The actual number employed depends on the number of codes supported by the terminal/system, operator settings, and system capacity.

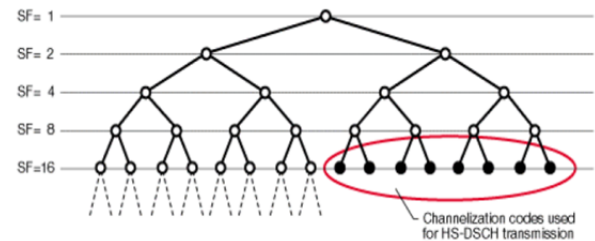

Figure 2 : Shared Channel transmission

2.1 Higher-order modulation

WCDMA 3GPP release 99 uses quadrature phase-shift keying (QPSK) modulation for downlink transmission. Besides QPSK, HS-DSCH can also use 16-quadrature amplitude modulation (16QAM) to provide higher data rates. Because 16QAM has twice the peak rate capability of QPSK it makes more efficient use of bandwidth than QPSK. Nevertheless, it also requires better radio channel conditions than QPSK.

Channel codes from the shared code resource are dynamically allocated every 2 ms or 500 times per second. A short TTI reduces roundtrip time and improves the tracking of channel variations—a feature that is exploited by link adaptation and channel-dependent scheduling. Although time is the primary way of sharing the “fat-pipe” resource among users, it is also possible to share resources in the code domain by using different subsets of the total HS-DSCH channel code set.

2.1.1 Fast Link Adaption

Radio channel conditions experienced by different downlink communication links vary significantly both in time and between different positions in the cell. Fast link adaptation adjusts the transmission parameters to instantaneous radio conditions and, when channel conditions permit, enables the use of high-order modulations.

WCDMA uses power control to compensate for differences and variations in the instantaneous radio channel conditions of the downlink. In principle, power control give communication links with bad channel conditions a proportionally larger part of the total available cell power. This ensures similar service quality to all communication links, despite differences in radio channel conditions. At the same time, radio resources are used more efficiently when allocated to communication links with good channel conditions. Thus, when seen in terms of overall system throughput, power control is not the most efficient means of allocating available resources[9].

Instead of using power control to compensate for rapidly varying radio conditions in the downlink, HS-DSCH relies on rate adjustment. That is, while keeping transmission power constant, it adjusts the data rate by changing the channel-coding rate.

Commonly known as rate adaptation or link adaptation, this method is more efficient than power control for services

that tolerate short-term variations in the data rate. What is more, to further increase peak data rates, HS-DSCH can use spectral-efficient 16QAM modulation when channel conditions permit.

2.1.2 Fast Scheduling

The fast-scheduling feature determines to which user equipment (UE) the shared channel transmission should be directed at any given moment. The objective is to transmit to users with favorable radio conditions.

The scheduler determines overall HSDPA performance. For each TTI, the scheduler decides which users the HS-DSCH should be transmitted to, and in close cooperation with the link adaptation mechanism, which modulation and how many codes should be used. This yields the actual end-user bit rate. Instead of sequentially allocating radio resources among users (round-robin scheduling), capacity can be increased significantly using channel-dependent scheduling. The aim of channel-dependent scheduling is to transmit to users with favorable instantaneous channel conditions.

2.1.3 Fast Hybrid ARQ

The UE can rapidly request the retransmission of missing data and combine information from the original transmission with that of the later transmission before attempting to decode the message. This approach, called soft-combining, increases capacity and provides robustness. A negative acknowledge (NACK) reply is sent when data is missing at the receiving end. An acknowledge (ACK) reply is sent when received data is correct. The fast HARQ operates with an n-channel stop-and-wait protocol.

The dual-channel structure guarantees continuous transmission, i.e. the protocol doesn't get stalled waiting for acknowledgements, as long as the roundtrip delay for the acknowledgements is short enough so that the response is always available when the slot for the same subchannels occurs again. Using a dual-channel approach brings benefits in receiver buffering requirements and decreases error probability in combining retransmissions with earlier received blocks. Only the amount of data corresponding to two TTI:s needs to be buffered in the receiver: One for each subchannel. If the transmission is not successful the retransmission takes place in the next TTI for the respective subchannel.

For the received data there is only two possibilities: It is either a new transmission or a retransmission of the previously transmitted block. Consequently, the soft combining of data can be done reliably.

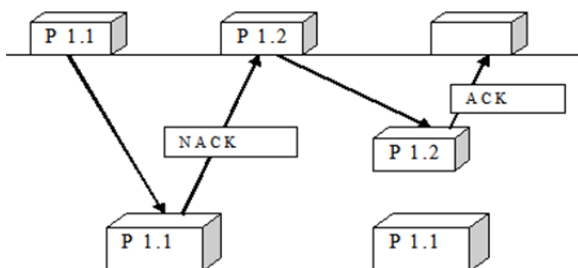

Figure 3 : Fast hybrid ARQ

Adaptive Modulation and Coding (AMC) is a fundamental feature of HSDPA. It consists of continuously optimizing the code rate, the modulation scheme, the number of codes employed and the transmit power per code based on the channel quality reported (CQI feedback) by the UE.

The HSDPA-capable UE can support the use of five, 10 and 15 multi-codes. A single user can receive up to 15 multi-codes resulting in a potential peak data rate of 10.8 Mbps. However, the maximum specified peak data rate with HSDPA is 14.4 Mbps (or 960 kbps/ code) when 16QAM modulation is used with no coding (effective code rate of one) and 15 multicodes.

The HSDPA-capable UE can support the use of five, 10 and 15 multi-codes. A single user can receive up to 15 multi-codes resulting in a potential peak data rate of 10.8 Mbps. However, the maximum specified peak data rate with HSDPA is 14.4 Mbps (or 960 kbps/ code) when 16QAM modulation is used with no coding (effective code rate of one) and 15 multicodes.

Another benefit of AMC is better utilization of the Node B power. If no power constraints are specified, the leftover power from the dedicated channels (R'99) can be allocated to HS-DSCH resulting in near-maximum power utilization. Should link errors occur, caused for example by interference, the mobile terminal rapidly requests retransmission of the data packets. In current WCDMA networks, these requests are processed by the RNC. In HSDPA, the request is processed in the base station, providing the fastest possible response.

In addition to **fast retransmissions**, incremental redundancy is also used. This technique selects correctly transmitted Bits from the original transmission and the retransmission to minimize the need for further repeat requests when multiple errors occur in transmitted signals. In WCDMA packet scheduling was the responsibility of the RNC. In HSDPA this is moved into the base station itself thereby significantly reducing the delay in reacting to changing conditions.

2.2 HSDPA Performance

HSDPA offers maximum peak rates of up to 10 Mbps in a 5 MHz channel. However, more important than the peak rate is the packet data throughput capacity, which is improved significantly. This increases the number of users that can be supported at higher data rates on a single radio carrier.

Another important characteristic of HSDPA is the reduced variance in downlink transmission delay. A guaranteed short delay time is important for many applications such as interactive games. In general, HSDPA's enhancements can be used to implement efficiently the 'interactive' and 'background' Quality of Service (QoS) classes standardized by 3GPP. HSDPA's high data rates also improve the use of streaming applications on shared packet channels, while the shortened roundtrip time will benefit web-browsing applications.

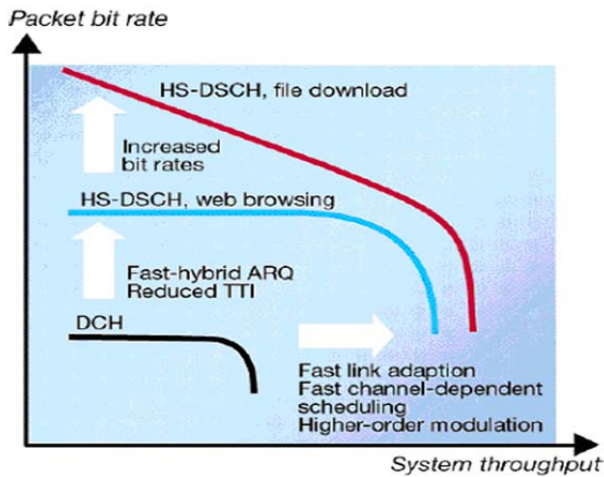

Figure 4.: Performance enhancement

2.3 Integral Part of WCDMA

Another benefit of HSDPA is that it is an integral part of WCDMA. Wide-area mobile coverage can be provided with HSDPA. It does not need any extra spectrum/carrier. At present, WCDMA can provide simultaneous voice and data services (multi-services) to users on the same carrier. This also applies to HSDPA, which means that spectrum can be used efficiently. HSDPA also makes efficient use of power by employing unused power.

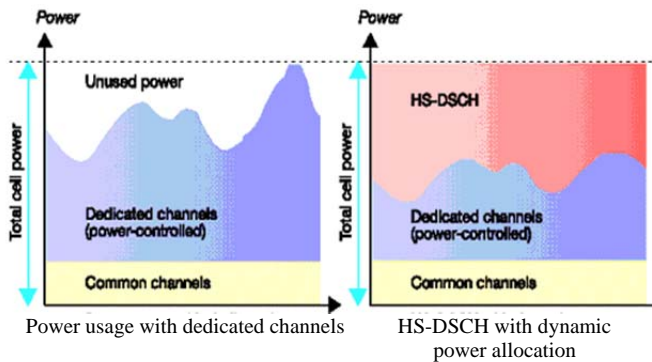

Figure 5. : Power utilization with and without HSDPA

3. TECHNOLOGY CAPABILITIES /COMPARISON

With data constituting a rising percentage of total cellular traffic, it is essential that operators deploy data technologies that meet customer requirements for performance and that are spectrally efficient, especially as data applications can demand significant network resources.

GPRS, now available globally, already makes a wealth of applications feasible, including enterprise applications, messaging, e-mail, Web browsing, consumer applications, and even some multimedia applications.

EDGE significantly expands the capability of GPRS, enabling richer Internet browsing, streaming applications, a greater scope of enterprise applications, and more multimedia applications.

Then with UMTS and HSDPA, users can look forward to video phones, high-fidelity music, rich multimedia

applications, and efficient access to their enterprise application.

Throughput requirement of various applications

- Micro browsing (e.g., WAP): 8 to 16 kbps
- Multimedia messaging: 8 to 32 kbps
- Video telephony: 64-384 kbps
- General purpose web browsing: 32 kbps to 384 kbps
- Enterprise applications, including e-mail, database access, virtual private networking: 32 kbps to 384 kbps
- Video and audio streaming: 32-384 kbps
- Given the successful transition from GPRS to EDGE, a performance gain of 2.5 to 3.5 for HSDPA can be anticipated with high confidence.
- Just as important as throughput is **network latency**, the round-trip time it takes data to traverse the network. Each successive data service reduces latency, with HSDPA expected to have latency approaching 100 msec. As data capabilities continue to improve, and the cost of service (e.g., \$ per Mbyte) decreases, not only will more existing networking applications become feasible for wireless networking, but more developers for both consumer and enterprise markets will see incentives to develop new content and applications

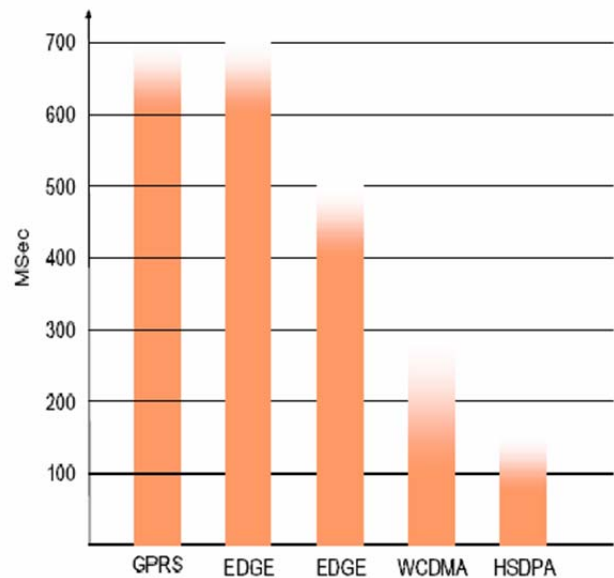

Figure 6.: Latency of different technologies

4. CONCLUSION:

The primary benefit of HSDPA is improved end-user experience. In practice, this means shorter download times through higher bit rates (14 Mbps peak rate) and reduced roundtrip time over the air interface. HSDPA also provides advantages for operators by introducing greater system capacity. HSDPA enhanced data rates and spectrum efficiency remains fixed, but the coding rate can vary between 1/4 and 3/4. The HSDPA specification supports

the use of 5, 10 or 15 multicodes. Link adaptation ensures the highest possible data rate is achieved both for users with good signal quality (higher coding rate), typically close to the base station, and for more distant users at the cell edge (lower coding rate).

The main end-user benefit of HSDPA for small objects transported via TCP is reduced roundtrip time thanks to hybrid-ARQ and short TTI. In contrast to web browsing, the slow-start mechanism in TCP has little or no impact on the time it takes to download a large file. Instead, the perceived end-user performance is largely determined by the data rate of the radio link. A single user downloading a large file can occupy a significant amount of the total cell capacity.

Consequently, system load has a substantial impact on the perceived performance when end-users download large files. Simulations show that in a lightly loaded system, HSDPA can reduce the time it takes to download large files by a factor of 20. HSDPA opens up for enhanced end-user experience when using WCDMA for Wireless Broadband Applications such as intranet and Internet access via laptop computers. Here the reduced delay improves the traditional web access. Download of emails and other heavy files are improved by the increased peak data rates.

5. FUTURE SCOPE:

A further benefit of HSDPA is greater system capacity. HSDPA increases capacity in several ways:

- Shared-channel transmission results in efficient use of available code and power resources in WCDMA.
- The use of a shorter TTI reduces roundtrip time and improves the tracking of fast channel variations.
- Link adaptation maximizes channel usage and enables the base station to operate close to maximum cell power.
- Fast scheduling prioritizes users with the most favorable channel conditions.
- Fast retransmission and soft-combining further increases capacity
- 16QAM yields higher bit rates. Depending on the deployment scenario, the combined gain in capacity is from two to three times that of WCDMA 3GPP release 99.
- HSDPA provides impressive enhancements over WCDMA R'99 for the downlink. It offers peak data rates of up to 10 Mbps, resulting in a better end user experience for downlink data applications (shorter connection and response times). More importantly, HSDPA offers three- to five-fold sector throughput increase, which results in significantly more data users on a single frequency. In fact, HSDPA allows a more efficient implementation of interactive and background Quality of Service (QoS) classes as standardized

by 3GPP. HSDPA high data rates improve the use of streaming applications, while lower roundtrip delays will benefit Web browsing applications.

- Another important benefit of HSDPA is its backwards compatibility with R'99. This makes its deployment very smooth and gradual on an "as needed" basis. The deployment of HSDPA is very cost effective since the incremental cost is mainly due to Node Bs and RNC upgrades. The ability to offer higher peak rates for an increasingly performance demanding end user at a substantially lower cost will create a significant competitive advantage for HSDPA operators. Supporting rich multimedia applications and content and more compelling devices at lower user cost will drive higher traffic per user and will enable early movers to differentiate themselves with advanced services — increasing their subscriber growth, data market share and profitability. Further enhancements (e.g. reduced latency, improvements for real-time services like VoIP, etc.) are well under way in standards through 3GPP Rel'7. Further, a long term evolution effort is in progress which is focused on ensuring that UMTS remains a highly-competitive packet-based radio-access technology through 2010 and beyond benefits.
- The first phase of HSDPA has been specified in 3GPP release 5. Phase one introduces new basic functions and is aimed to achieve peak data rates of 14.4 Mbps. Newly introduced are the High Speed Downlink Shared Channels (HS-DSCH), the adaptive modulation QPSK and 16QAM and the High Speed Medium Access protocol (MAC-hs) in the Node-B.
- The second phase of HSDPA is specified in the upcoming 3GPP release 7 and has been named HSPA Evolved. It can achieve data rates of up to 42 Mbps. It will introduce antenna array technologies such as beamforming and Multiple Input Multiple Output (MIMO). Beam forming can be described as focusing the transmitted power of an antenna in a beam towards the user's direction. Deployments are scheduled to begin in the second half of 2008. After HSDPA the roadmap leads to HSOPA, a technology under development for specification in 3GPP Release 8. This project is called the LTE (Long Term Evolution) initiative. It aims to achieve data rates of up to 200 Mbps for downlink and 100 Mbps for uplink using OFDMA modulation. In this project I have tried to simulate an antenna patch to get the 1.9 GHz frequency for GSM/HSDPA operation with the help of IE3D simulation and optimization software.

TECHNOLOGIES	PEAK NETWORK DOWNLINK SPEED	AVERAGE USER THROUGHPUTS FOR FILE DOWNLOADS	CAPACITY	OTHER FEATURES
GPRS	115 Kbps	30-40 Kbps	-	-
EDGE	473 Kbps	100-130 Kbps	Double that of GPRS	Backward compatible with GPRS
UMTS-WCDMA	2 Mbps	220-320 Kbps	Increased over EDGE for high bandwidth applications	Simultaneous voice and data operations, enhanced security, qos, multimedia support, and reduced latency
WCDMA-HSDPA	14 Mbps	550-1100 Kbps	Two and a half to three and a half times that of WCDMA	Backward compatible with WCDMA

Figure 6: Comparison table

REFERENCES:

- [1] Abdelali El Bouchti, "Optimal admission control in high speed downlink packet access network" 2016 Fifth International Conference on Future Generation Communication Technologies (FGCT)
- [2] Arnab Das; Nandu Gopalakrishnan; Teck Hu; Farooq Khan; Ashok Rudrapatna; Ashwin Sampath; Hsuan-Jung Su; Said Tatesh; Wenfeng Zhang, "Evolution of UMTS toward high-speed downlink packet access", Bell Labs Technical Journal ,Year: 2003, Volume: 7 ,issue 3.
- [3] Tao Cui; Feng Lu; Vignesh Sethuraman; Anil Goteti; Subramanya P. N. Rao; "Throughput Optimization in high speed downlink packet access" IEEE Transactions on wireless communication, 2011
- [4] Man Young Rhee, "High Speed Downlink Packet Access (HSDPA) Mobile Communication Systems and Security, IEEE 2009
- [5] Tsan-Pin Wang; Wei-Han Tseng, " Two- Phase Packet scheduling for UMT High Speed Downlink Packet Access, 2010 International Conference on Electronics and Information Engineering, IEEE Conference Publications
- [6] Kandaraj Piamrat; Kamal Deep Singh; Adlen Ksentini; Cesar Viho; Jean-Marie Bonnin, "QoE-Aware Scheduling for Video-Streaming in High Speed Downlink Packet Access", 2010 IEEE Wireless Communication and Networking Conference
- [7] Hassaan Touheed; Atta Ul Quddus; Rahim Tafazolli, "An Improved Link Adaptation Scheme for High Speed Downlink Packet Access VTC Spring 2008 - IEEE Vehicular Technology Conference
- [8] R. Kwan; M. E. Aydin; C. Leung; J. Zhang "Multiuser scheduling in high speed downlink packet access" , IET Communications 2009, Volume: 3, Issue: 8
- [9] Kamal Deep Singh; Julio Orozco; David Ros; Gerardo Rubino "Improving Perceived Streaming-Video Quality in High Speed Downlink Packet Access IEEE GLOBECOM 2008 - 2008 IEEE Global Telecommunications Conference
- [10] M. P. J. Baker; T. J. Mouldsley " Evolution of High Speed Downlink Packet Access in WCDMA by improved ARQ signalling", 2005 6th IEEE International Conference on 3G and Beyond.
- [11] Klaus Ingemann Pedersen; Frank Frederiksen; Troels Emil Kolding; Tako Freerk Lootsma; Preben E. Mogensen, "Performance of High-Speed Downlink Packet Access in Coexistence With Dedicated Channels" IEEE Transactions on Vehicular Technology Year: 2007, Volume: 56, Issue: 3
- [12] Soo-yong Jeon; Dong-ho Cho, " Channel Adaptive CQI Reporting Schemes for UMTS High-Speed Downlink Packet Access" , IEEE Vehicular Technology Conference, 2006